

Directions for Setting the Price on VR-10 Computers

See PMP website for instructional videos: www.pmp-corp.com

From \$0.000 to \$0.999 (1/10¢ Price Increment)

- 1) Set price wheels by positioning and fully engaging range arms (see Figure 1).
- 2) Move dollar shift lever to "central" position (see Figure 2).
- 3) Set price range shift lever in the "L" or "1/10" position (see Figure 3).
- 4) Dollar drive shaft vertical pin is installed (see Figure 4).
- 5) Color coded idler gears not engaged (see Figure 5).
- 6) Dollar price wheel should be in "blank" position. If not, remove cotter pin, lift wheel, turn into position, lower wheel, and replace cotter pin.

From \$1.000 to \$1.999 (1/10¢ Price Increment)

- 1) Set price wheels by positioning and fully engaging range arms (see Figure 1).
- 2) Move dollar shift lever to "100" position (see Figure 2).
- 3) Set price range shift lever in the "L" or "1/10" position (see Figure 3).
- 4) Dollar drive shaft vertical pin is installed (see Figure 4).
- 5) Color coded idler gears not engaged (see Figure 5).
- 6) Dollar price wheel should be in "1" position. If not, remove cotter pin, lift wheel, turn into position, lower wheel, and replace cotter pin.

From \$2.000 to \$2.999 (1/10¢ Price Increment)

- 1) Set price wheels by positioning and fully engaging range arms (see Figure 1).
- 2) Move dollar shift lever to "200" position (see Figure 2).
- 3) Set price range shift lever in the "L" or "1/10" position (see Figure 3).
- 4) Dollar drive shaft vertical pin is installed (see Figure 4).
- 5) Color coded idler gears not engaged (see Figure 5).
- 6) Dollar price wheel should be in "2" position. If not, remove cotter pin, lift wheel, turn into position, lower wheel, and replace cotter pin.

From \$3.000 to \$3.999 (1/10¢ Price Increment)

- 1) Set price wheels by positioning and fully engaging range arms (see Figure 1).
- 2) Move dollar shift lever to "200" position (see Figure 2).
- 3) Set price range shift lever in the "L" or "1/10" position (see Figure 3).
- 4) Remove dollar drive shaft vertical pin (see Figure 4 on page 3 and photos on page 4).
- 5) White color coded gear engaged (see Figure 6).
Detail: Remove cotter pin. Remove gear group. Remove washer. Install white gear onto green gear. Install black gear, hub side down, onto green gear. Install red gear, hub side up, onto green gear. Install gear group on shaft. Install washer. Install cotter pin.
- 6) Move dollar price wheel to "3" position.
Detail: Remove cotter pin, lift wheel, turn into position, lower wheel, and replace cotter pin.



A Veteran Owned and Managed Company

PMP CORPORATION
P.O. Box 422 - 25 Security Drive
Avon, CT 06001

Local: 860-677-9656
Toll Free: 800-243-6628
Toll Free Fax: 888-674-0196
Web: www.pmp-corp.com
E-mail: sales@pmp-corp.com



© PMP CORP

From \$4.000 to \$4.999 (1/10¢ Price Increment)

- 1) Set price wheels by positioning and fully engaging range arms (see Figure 1).
- 2) Move dollar shift lever to "200" position (see Figure 2).
- 3) Set price range shift lever in the "L" or "1/10" position (see Figure 3).
- 4) Remove dollar drive shaft vertical pin (see Figure 4 on page 3 and photos on page 4).
- 5) Red color coded gear engaged (see Figure 7).
Detail: Remove cotter pin. Remove gear group. Remove washer. Restack red then black gears upside down on green gear. Install white gear on black gear. Install gear group on shaft. Install washer. Install cotter pin.
- 6) Move dollar price wheel to "4" position.
Detail: Remove cotter pin, lift wheel, turn into position, lower wheel, and replace cotter pin.

From \$5.000 to \$5.999 (1/10¢ Price Increment)

- 1) Set price wheels by positioning and fully engaging range arms (see Figure 1).
- 2) Move dollar shift lever to "200" position (see Figure 2).
- 3) Set price range shift lever position to the "L" or "1/10" position (see Figure 3).
- 4) Remove dollar drive shaft vertical pin (see Figure 4 on page 3 and photos on page 4).
- 5) Black color coded gear engaged (see Figure 8).
Detail: Remove cotter pin. Remove gear group. Remove washer. Install black gear group upside down on green gear. Install white then red gears on black gear. Install gear group on shaft. Install washer. Install cotter pin.
- 6) Move dollar price wheel to "5" position.
Detail: Remove cotter pin, lift wheel, turn into position, lower wheel, and replace cotter pin.

From \$0.00 to \$9.99 (1¢ Price Increment) - (This price setting is typically used from \$5.00-\$9.99)

- 1) Install the dollar drive shaft vertical pin (see Figure 4 on page 3 and photos on page 4).
- 2) Color coded gears are not engaged. Install cotter pin so that they are suspended above washer (see Figure 5), or remove gears entirely and store for possible later use.
- 3) Move price range shift lever to the "H" or "1" position (see Figure 3).
- 4) Move dollar shift lever to "central" position (see Figure 2).
- 5) Move dollar price wheel to "blank" position.
Detail: Remove cotter pin, lift wheel, turn into position, lower wheel, replace cotter pin.
- 6) Set price by positioning and fully engaging three range arms (see Figure 1).
- 7) Move decimal point on faceplates one position to the right.

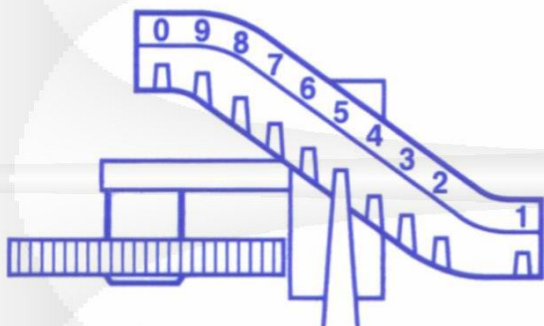

FIGURE 1

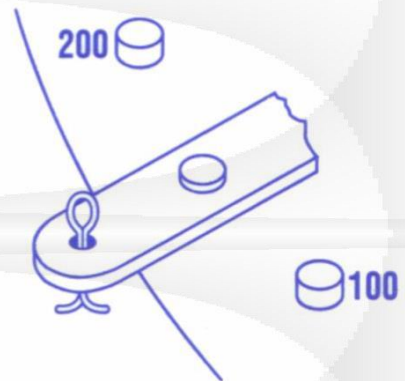

FIGURE 2

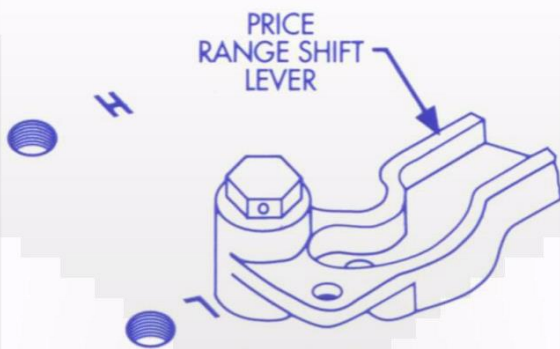

FIGURE 3

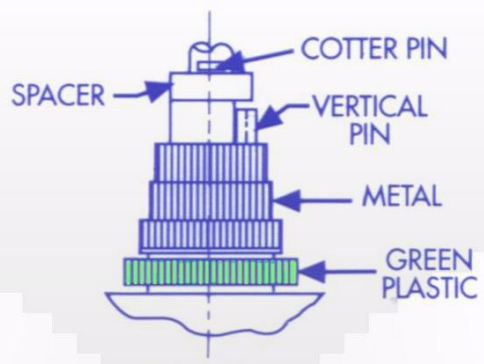
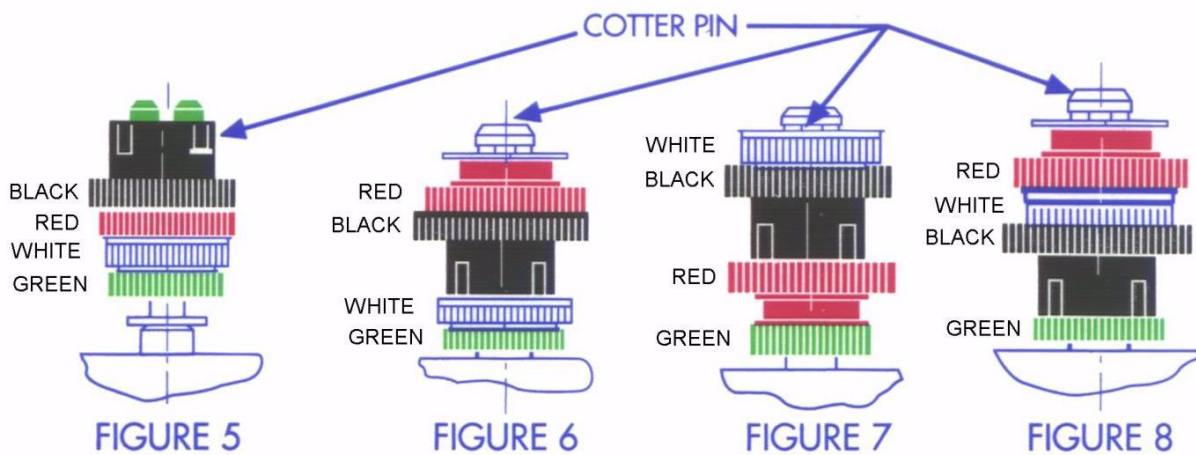

FIGURE 4



EXAMPLE: INSTALLATION OF THE DOLLAR DRIVE SHAFT VERTICAL PIN

(For removal of the vertical pin, reverse the steps)

Note: If the top money wheel banks are not turning, the vertical pin needs to be installed.

Note: PMP computers come standard with a vertical pin stored in a plastic bag and attached to the top dust cover. The vertical pin can also be purchased individually as PMP p/n 81014



REMOVE COTTER PIN



**LIFT SPACER AND
INSTALL VERTICAL PIN**



**LOWER SPACER AND
RE-INSTALL COTTER PIN**

If you have questions or need additional assistance, call PMP at 1-800-243-6628 or visit www.pmp-corp.com

All product or company's names, trade names, trademarks, parts numbers and part descriptions may be the trademarks of their respective owners, and are used for reference or identification purposes only. PMP does not claim any right to or affiliation with such owners. The PMP product described here is manufactured or remanufactured and sold by PMP and is not the product of any other identified manufacturer.