

Troubleshooting Notes:

Problem	Cause	Solution
Incorrect count, erratic count, or missing pulses at the console.	Sensor is out of position so the gear teeth are no longer breaking the sensor beam or only breaking the beam intermittently.	Check for correct position of sensor. Ensure the nut holding sensor bracket is tight.
Sensor is binding and/or chattering.	The Rapid-Fire sensor is not centered over the register gear and the gear is rubbing against the sensor.	Check for correct position of sensor. Reposition sensor with gear in the center. Ensure the nut holding sensor bracket is tight.
Pulser won't count on installation.	Loose or improper wiring connections	Recheck wiring connections.
	Damaged wiring	Repair wires or replace pulser.
	Dirty sensor "eyes"	Used canned compressed air to remove dust/debris blocking sensor beam.
	Broken/cracked sensor	Replace pulser
	Pulser is not compatible with console model	Call PMP for technical assistance. 800-243-6628

Specifications:

Input Voltage Range	Electronic Console Pulse Circuit Range	Operating Temperature	Operating Speed
70 VAC to 130 VAC	5 to 400 VAC/DC	-40°F to +160°F -40°C to +71°C	Exceeds Meter-Register maximum speeds*

*Rapid-Fire Pulser tested to a speed of 600 RPM

Wiring Connections:

Rapid-Fire Pulser #48505	Black Wire	White Wire	Blue Wire	Blue Wire
115 VAC Pulser	115 VAC Hot	Neutral	Pulser Circuit	Pulser Circuit
			These wires are interchangeable.	

Manufacturers' numbers, names, trade names, trademarks and descriptions used here are for reference purposes only. None of the rebuilt items listed in this manual is the product of the identified manufacturer.

PMP FR/W Rapid-Fire™ Pulser

For use on Fill-Rite® and Wayne® Meter-Registers

Installation Instructions

PMP #48505

for 115 VAC



These instructions are to be used when installing the FR/W Rapid-Fire Pulser in Fill-Rite and Wayne Meter-Registers.

INTRODUCTION

The Rapid-Fire Pulser is an intrinsically safe, easy to install pulsing device. The FR/W will work on Fill-Rite 800 and 900 series and the Wayne 700 series meter-registers.

The Rapid-Fire Pulser can interface with any electronic console pulse circuit from 5 to 400 VAC/DC, with a current requirement not exceeding 100 MA.

WARNING Before installing the Rapid-Fire Pulser, **TURN OFF** all circuit breakers that control power to the dispenser to be serviced. Take adequate precautions to prevent circuit breakers from being turned on until all work has been completed. More than one circuit breaker may have to be **TURNED OFF** to completely disconnect the power. Failure to comply with this warning could result in serious personal injury, equipment damage, property damage and even death.

The FR/W PMP Rapid-Fire Pulser consists of two components: the barrier, which is connected to the dispenser's junction box, and the sensor that mounts on the internal counting mechanism of the register.

Contents



- 1 – Barrier hardwired to optical sensor
- 2 – Cable ties
- 2 – Push nuts
- 1 – Push nut tool
- 4 – Wire nuts
- 1 – FR/W installation instructions

Tools needed



- 1 – Phillips head screwdriver
- 1 – Channel lock pliers
- 1 – Small adjustable wrench
- 1 – 5/16" Nut driver
- 1 – Wire-cutters to trim tie wraps
- 1 – Rat-tail file
- 1 – Hacksaw
- 1 – 1/4" Drill bit
- 1 – 3/8" Drill

Rapid-Fire Barrier Installation. (See Figure A)

1. Turn off all power to the junction box.
2. Remove dispenser junction box cover.
3. Remove a plug from a 3/4" NPT location that will allow clearance for the 6" length of the barrier. If the junction box uses 1/2" threaded connections, use a 3/4" to 1/2" coupling to connect the barrier to the junction box.
4. Install the barrier by screwing it into a 3/4" hole at least five (5) full turns.

NOTE: The Rapid-Fire Pulser is not designed for use with 220V. Connecting to a 220V circuit will render the pulser inoperable and beyond repair.

5. Attach the black and white barrier wires to a "switched" 115 VAC circuit.

The circuit must be "hot" when the dispenser is in use and "dead" when the operating handle is turned off.

NOTE: This step must be performed properly. The pulser must be connected to a circuit which will turn off between sales to maintain accuracy and ensure reliable operation.

6. Attach the blue barrier wires to the "pulse circuit" from the console. (These wires are interchangeable.)
7. Re-install the junction box cover.

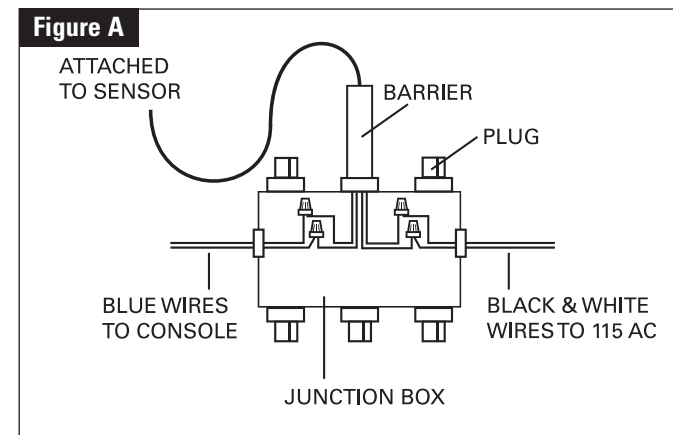

The FR/W Rapid-Fire Pulser was designed for the Fill-Rite 800 and 900 series meter-registers and the Wayne 700 series meter-registers.

NOTE: There are several variations of these meter-registers. Installation may vary slightly depending on the specific model.

1. Remove cover from register.
2. Remove the two screws holding the counter to the housing and remove counter.
3. Locate the hex-nut if present on right side (closest to the slot on frame) and loosen approximately three turns. (See Figure B)

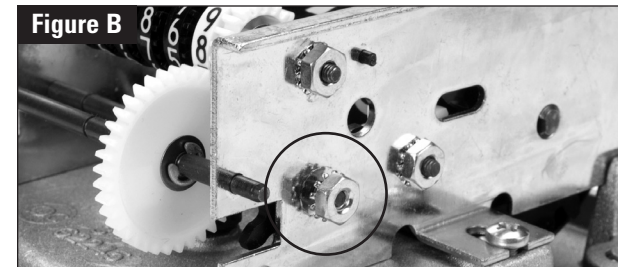

4. Slide the bracket along right side of register until the slot in the sensor bracket is captured with the register mounting screw. The tab on the bracket fits under the housing of the register. (See Figure C) The optical sensor should fit into the slot on the register's right side. (See Figures D and E)

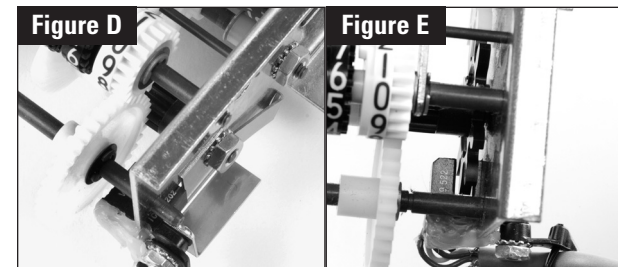
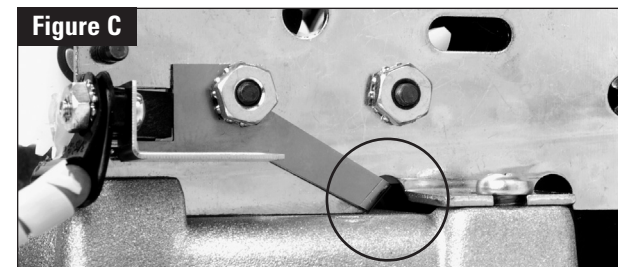

5. Hold the sensor assembly in place and tighten the mounting nut or install push nut on plain shaft. (See Figure F) Check the alignment of the optical sensor. The gear should be centered in the slot of the optical sensor.

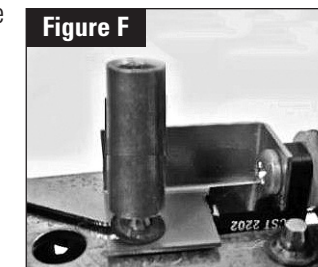

6. Use a drill with a 1/4" bit, a hacksaw and/or a rat-tail file to make a notch in the register housing for the sensor wire to pass through. The slot should be just deep enough to allow the cover to fit without pinching the sensor wire. (See Figure G for Fill-Rite & Figure H for Wayne)

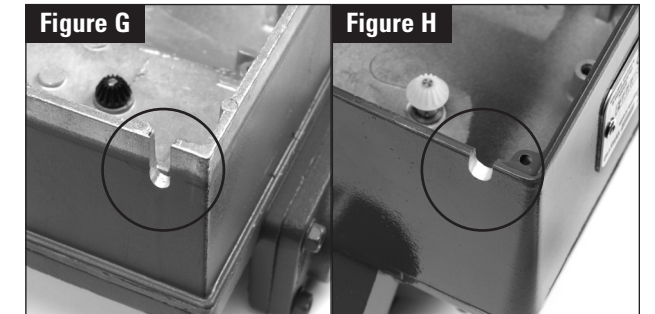

7. Reinstall the counter in the register housing and reinstall the two screws holding the counter to the housing. (See Figure I for Fill-Rite & Figure J for Wayne)

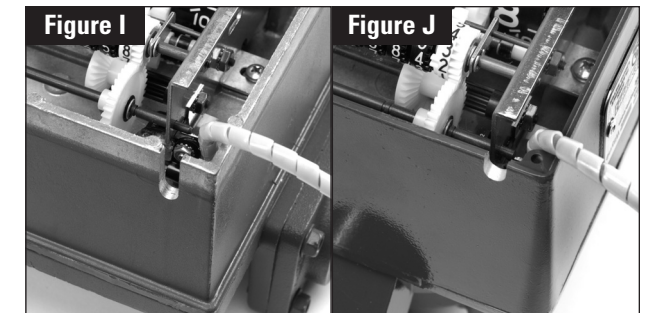

8. Route the sensor wire through slot. Position the spiral cable protector to cover the cable as it passes through the new slot in the housing. (See Figure K for Fill-Rite & Figure L for Wayne)

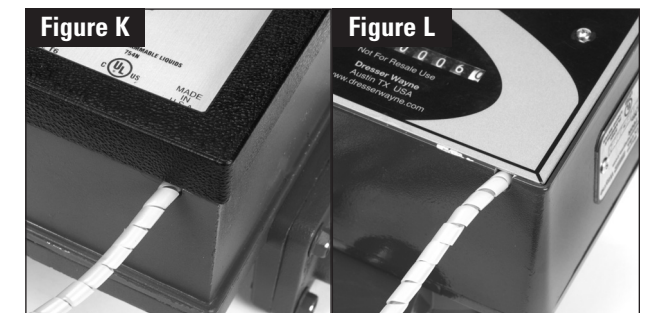

9. Check to ensure the sensor cable is not pinched or interfering with the register mechanism and install register cover.
10. Apply power to the equipment.
11. Test the system by pumping fuel into an approved container.
12. If you have any questions, call 1-800-243-6628.