



**PMP
CORPORATION**

Manual Number: **01-**
Revision : **4**
Date: **7/11/2023**

Installation Instructions

New PMP Fiberglass Tank Interstitial Sensor

PMP # 63409

Replaces Veeder-Root #794390-401, -404, -407, -409

Contents

Disclaimer.....	2
Related Manuals	2
Safety Symbols	3
BEFORE YOU BEGIN.....	3
SAFETY PRECAUTIONS FOR INSTALLATION AND MAINTENANCE	4
Description	4
Sensor Models.....	4
In the box	4
Installation Prep	5
Sizing the Sensor	5
Installation of the Sensor	6
Verifying proper orientation	6
Complete the installation.....	7
Functional / Maintenance Test Procedure.....	8
Quick Reference	8
Installation and Operation manuals.....	8
Equipment Check Guidelines	8
Equipment Calibration	8
Maintenance Procedures	8
Test Results/Reports	8
Technical Contact	8

Disclaimer

All product or company's names, trade names, trademarks, parts numbers and part descriptions may be the trademarks of their respective owners, and are used for reference or identification purposes only. PMP does not claim any right to or affiliation with such owners. The PMP product described here is remanufactured and sold by PMP and is not the product of any other identified manufacturer.









Related Manuals

This installation requires specific knowledge of Veeder-Root® equipment and you may need to refer to the following OEM manuals to complete the installation:

576013-879	TLS-3XX Series Console Site Prep and Installation Manual
577013-879	TLS-4XX Series Console Site Prep and Installation Manual
576013-617	Interstitial Liquid Sensor – Fiberglass Tanks Installation Guide
577013-750	Sensor Product Application Guide
577013-814	Operability Testing Guide

Safety Symbols

The following safety symbols are used to alert you to potential hazards and precautions that should be taken. These symbols are not intended to alert you to all of the potential hazards you could be exposed to while working in a service station environment. These symbols cannot replace common sense and industry practices.

	Read and understand all of the written material related to the installation of this product. If you are un-sure of any aspect of this product, contact PMP for clarification.
	Attention. Pay particular attention to the text adjacent to the use of this symbol to alert you to safety or operational issues.
	Remove / disconnect all power before proceeding with this installation.
	Potential shock hazard. Test circuit to verify power has been disconnected.
	Cordon off work area with barriers to avoid contact with traffic.
	Potentially explosive materials and or atmosphere. Take necessary precautions.
	Potentially flammable materials and or atmosphere. Take necessary precautions.
	Electro-static discharge hazard has the potential to damage sensitive electronic equipment

BEFORE YOU BEGIN



- Service station equipment has both electricity and hazardous, flammable and potentially explosive liquid. Failure to follow the precautions below and instructions in this guide may result in serious injury and death. Follow all rules, codes and laws that apply in your area.
- Veeder-Root requires training certifications for contractors who install and set up equipment related to the TLS-350. Installers of this product must have a Veeder-Root® certification of Level 2/3. Be sure that you have familiarized yourself with these requirements and determined if you are qualified to perform this installation.



- PMP shall not be liable for errors contained herein or for incidental or consequential damages in connection with furnishing, performance or use of this publication.
- PMP reserves the right to change product features or the information contained in this publication.
- Failure to install this product in accordance with OEM instructions and warnings will result in voiding of all warranties connected with this product and may damage the environment.

SAFETY PRECAUTIONS FOR INSTALLATION AND MAINTENANCE

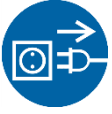

- Only a person with knowledge and experience with service station equipment should perform this work.



- Always make sure ALL power to the equipment you are working with is turned OFF before starting any maintenance.



- Note that more than one disconnect switch may be required to de-energize the equipment for maintenance and servicing. Use a voltmeter to make sure ALL circuits in the dispenser are de-energized. Failure to do so may result in serious injury.

Description

PMP Corporation’s 63409 interstitial sensors are designed to work in tanks between 4’ and 12’. The sensor detects the presence of fluid in the interstitial space of a double wall fiberglass tank. If the liquid level in the interstitial space of a fiberglass tank rises above the threshold of the 62401, 62404, 62407 or 62409 sensors, an alarm is generated and logged in the ATG console so that a historical record of the alarm due to the change in position is recorded. This alarm would indicate there is liquid present in the interstitial space where the sensor is installed. The sensor can easily be removed, cleaned and reinstalled if an alarm is triggered or for periodic testing.

Sensor Models

PMP Number	OEM Number	Description
63409	794390-401	Sensor for 4’-12’ Diameter Fiberglass Tank

In the box

Contents	Qty
Fiberglass Sensor	1
Installation instructions	1
Cable tie wrap,	
Wire nut, P2 blue	2
Rubber insert for cord-grip	2
Cord-grip, 1/2 NPT	2
3M Scotchcast™ Seal Pack	1

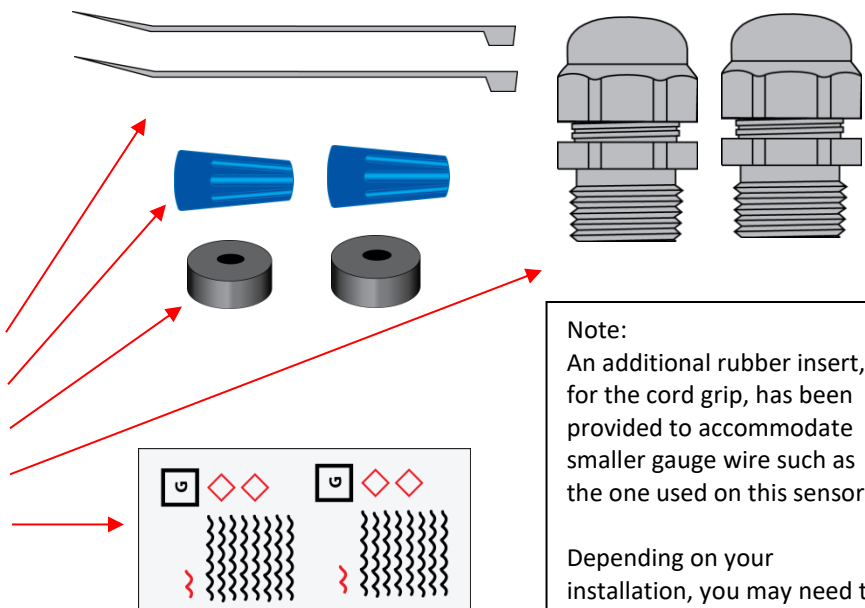

Note:
An additional rubber insert, for the cord grip, has been provided to accommodate smaller gauge wire such as the one used on this sensor.

Depending on your installation, you may need to replace the rubber insert to ensure a water tight connection.



Installation Prep

1. Turn-off power to the system.
2. Block off the work area.



3. Confirm that there is no liquid in the interstitial space prior to installing the sensor.
4. Installation of the Fiberglass Interstitial sensor requires a rope or pull cord be installed in the interstitial space of the tank. If there is no pull cord available, you may need to fish a pull cord through the riser and around the tank prior to installation.



Sizing the Sensor

1. It is important to know the diameter of the tank before starting the installation. A proper installation requires that the sensor rest at the lowest part of the tank (usually at the point which is half the circumference of the tank).
2. The sensor has been color coded to aid installation and provide options depending on your site configuration. These colors represent the approximate half-way point for 4', 6', 8', 10' and 12' diameter tanks.

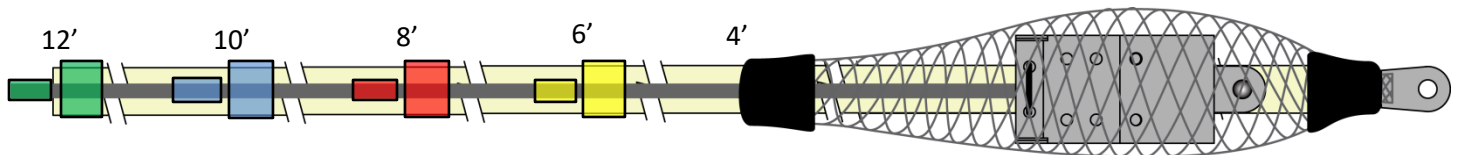

Tank Diameter	Color	Approximate distance to center of sensor housing (reference only)
4'	Black	76"
6'	Yellow	113"
8'	Red	152"
10'	Blue	188"
12'	Green	226"

3. Depending on your installation preference, you may want to leave the strap intact to allow you to "push" the sensor into the interstitial space. However, if you are replacing an existing sensor and are confident you can pull the sensor through the interstitial space easily, you may want to trim the excess strap and only leave the colors necessary to properly place the sensor.

Example:

If you are installing the sensor in an 8' diameter tank, cut the strap at the 8' mark and remove the excess. Be careful not to cut or damage the wire.

After you have cut the nylon strap to the desired length, it is recommended that you wrap electrical tape around the cut end to prevent the strap from bunching-up if the sensor needs to be removed.

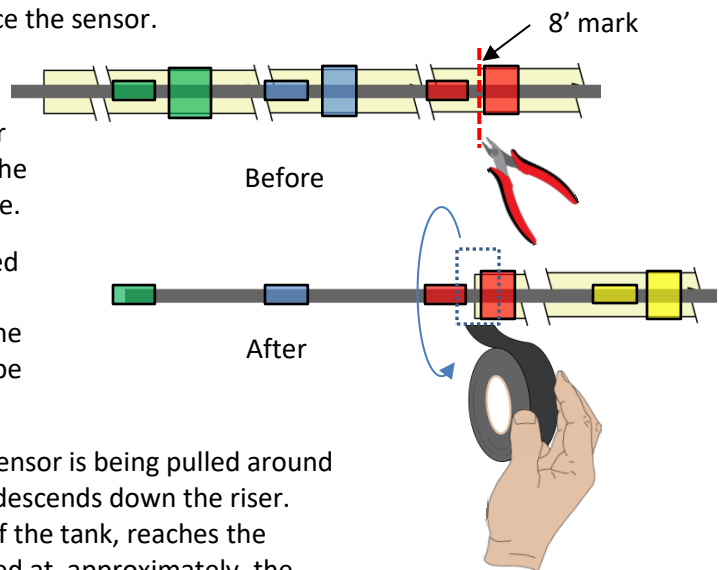

4. The colors are positioned such that when the sensor is being pulled around the tank, each color can be read as the sensor descends down the riser. When the color which coincides with the size of the tank, reaches the bottom of the riser, the sensor should be located at, approximately, the half-way point.

Installation of the Sensor



Note: You must refer to the OEM manuals listed earlier in this manual for detailed instructions including console setup.



5. This installation requires that a pull cord be in place prior to attempting to install the sensor.



6. A proper installation requires that the sensor rest at the lowest part of the tank (usually at the point which is half the circumference of the tank).

7. Tie the pull cord to the sensor using the hole provided at the head of the sensor.

8. While pulling the cord, feed the sensor into the riser pipe and pay close attention to the orientation of the sensor head as it enters the interstitial space.

9. The sensor must enter the interstitial space upside-down in order to be in the proper orientation at the bottom of the tank.

10. Use the color markings along the sensor as a guide to approximate the sensor location relative to the bottom of the tank. For example, when the red marking for an 8' tank reaches the bottom of the riser, this represents the approximate half-way point for an 8' diameter tank.

11. Position the sensor at the bottom of the tank. This may require that additional steps be taken or measurements be taken to ensure that the sensor is at the very bottom.

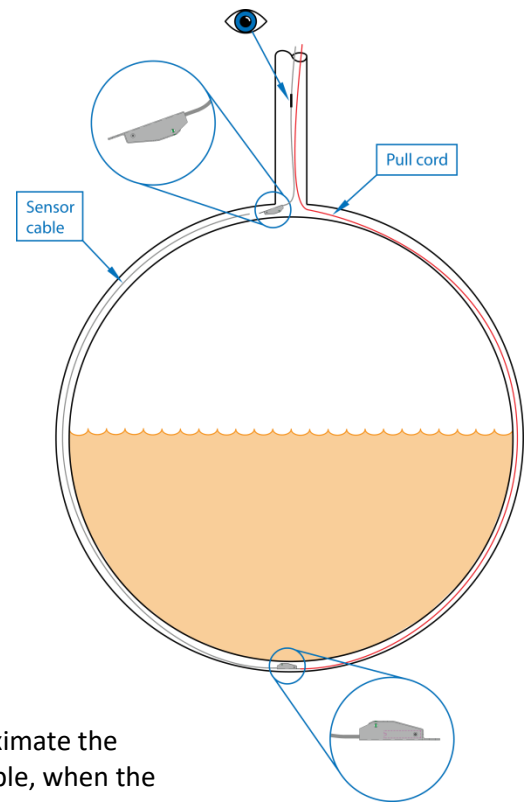

Verifying proper orientation

1. Verify that the sensor has been installed in the proper orientation.

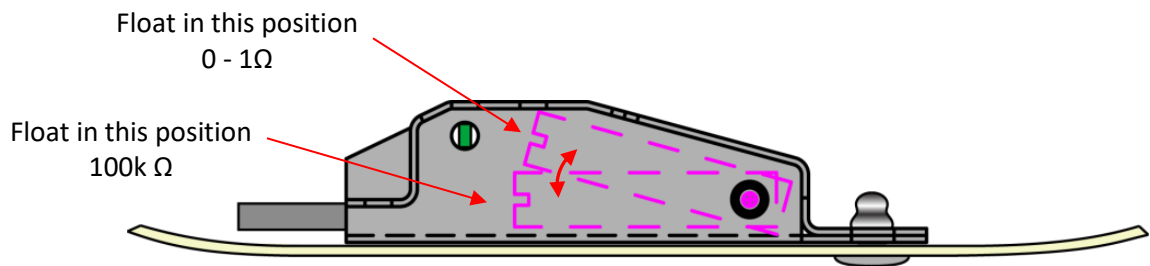

2. Connect an ohm meter to the two wire cable of the sensor.



3. The ohm meter must read 100k ohms after installation. If the ohm meter reads 0 ohms, this indicates that the sensor is upside-down and the sensor must be re-installed in the correct orientation.

Note: You can confirm proper orientation by using an ohm meter across the sensor wires:

100k Ω = ✓

0 Ω = ✗

Complete the installation

1. Feed the sensor cable through the riser cap and cord grip. Tighten the cord grip.
2. Install the cap on the riser.
3. Using the wire nuts provided, connect the sensor to the field wiring in accordance with applicable codes.
4. Place the field wiring in the Connector Sealing Pack provided. See instructions below on how to use the Connector Sealing Pack.

How to use the Connector Sealing Kit

1. Carefully cut the bag and remove the seal pack.
2. Remove the two part seal pack.

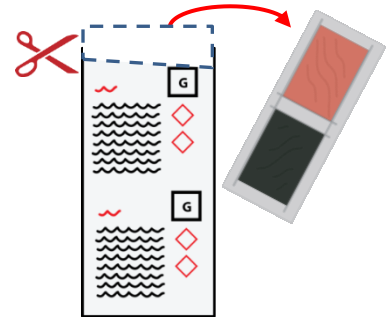

3. Grip the edges of the seal pack at the center and vigorously wiggle the plastic bag to weaken the barrier between the two halves.

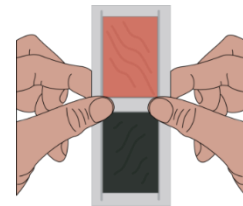

4. Squeeze the resin back and forth 25-30 times to thoroughly mix the two parts.

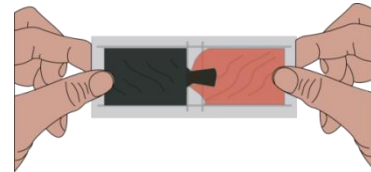

5. Squeeze the mixed resin to one side of the packet to allow enough room to cut the top of the pack.

6. Cut the top of the pack off.

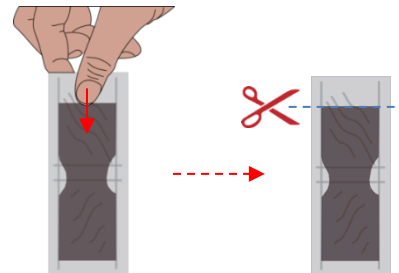

7. Insert the connections made above. **Be sure the connections are inserted to the full depth of the seal pack to ensure a watertight connection.**

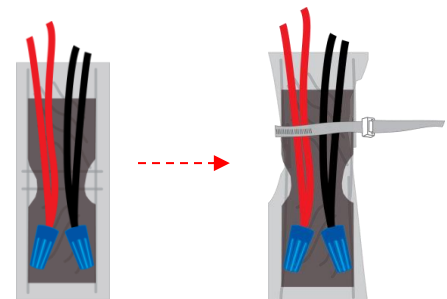

8. Use the wire tie provided to cinch the packet, where shown, to secure the wires in the epoxy pack during the curing process.

Cure time is approximately 8-12 min @ 73°F.



Functional / Maintenance Test Procedure

1. Fill a container with a minimum of 2 inches of water.
2. Remove sensor from tank or sump.
3. Inspect the sensor for any physical damage including cables and connections.
4. Place the sensor in the container, oriented as it would be installed, until the bottom 2 inches of the sensor are submerged.
5. The sensor should trigger an alarm on the TLS. Depending on the console and site configuration, it may take up to 5 minutes to trigger an alarm.
6. Clear the alarm on the TLS-350 by pressing the Alarm / Test key or pressing the Alarm button twice on the TLS-450.
7. **If an alarm is not detected, the sensor has failed the test and must be replaced.**
8. If the sensor passed the test, allow the sensor to dry and reinstall per the installation instructions.
9. Record the test results for your records.

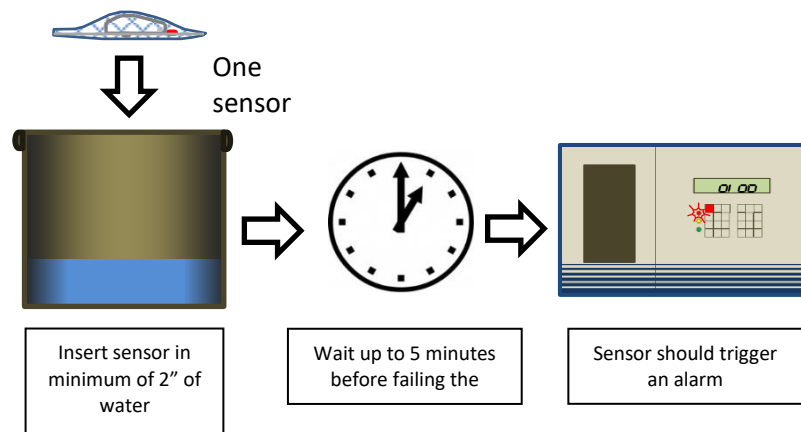

Quick Reference

Installation and Operation manuals

PMP provides an overview of the sensor installation with each sensor shipped. These installation overviews can also be found on the internet at www.pmp-corp.com. Refer to the OEM manuals listed page 2 for detailed installation instructions.

Equipment Check Guidelines

No vendor specific checklist is provided for the equipment used to monitor these sensors. However, the EPA provides a useful checklist for Underground Storage Tank (UST) owners. This checklist is available on the EPA's website:

www.epa.gov/oust/cmplastc/cheklist.pdf

Equipment Calibration

No calibration is required for the sensors discussed in this document.

Maintenance Procedures

Periodic maintenance may be required by local regulations. Operability test guidelines for each sensor can be obtained from PMP or be found on the internet at www.pmp-corp.com. Sensors should be tested at least annually. However, Federal, State or Local regulations may require more frequent inspections and testing.

Test Results/Reports

Third party evaluations were conducted by Ken Wilcox and Associates. Test results can be obtained from PMP.

Technical Contact

Support questions can be directed to the Engineering department at PMP. Refer to the contact information printed at the bottom of this page.



PMP CORPORATION

P.O. Box 422 • 25 Security Drive
Avon, CT 06001

E-mail: sales@pmp-corp.com

Local: 860-677-9656

Toll Free: 800-243-6628

Toll Free Fax: 888-674-0196

Web: www.pmp-corp.com



© PMP CORP.